

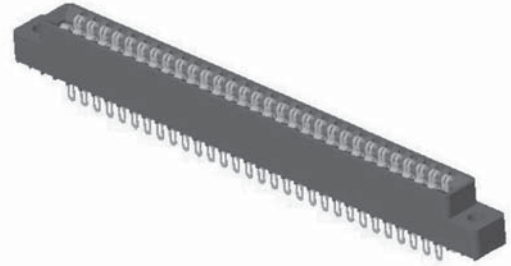

.125" [3.18mm] Contact Centers, .431" Insulator Height
Dip Solder/Eyelet/Right Angle for .062" [1.57] or .031"[0.79] Mating PCB

SPECIFICATIONS

- Accommodates .062" ± .008" [1.57 ± .20] PC board (Consult factory for .031" ± .008" [.79 ± .20], .093" ± .008" [2.36 ± .20] and .125" ± .008" [3.18 ± .20] boards)
- Molded-in key available
- 3 amp current rating per contact
- 30 milli ohm maximum at rated current



Sullins Edgecards

READOUT

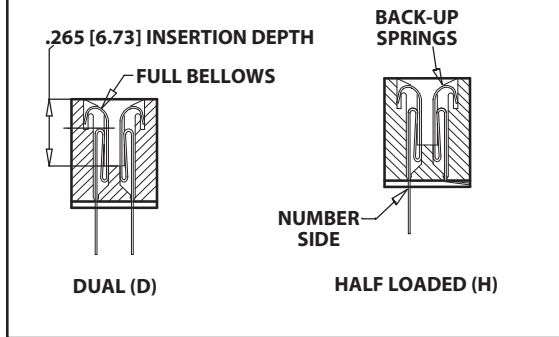

POLARIZING KEY

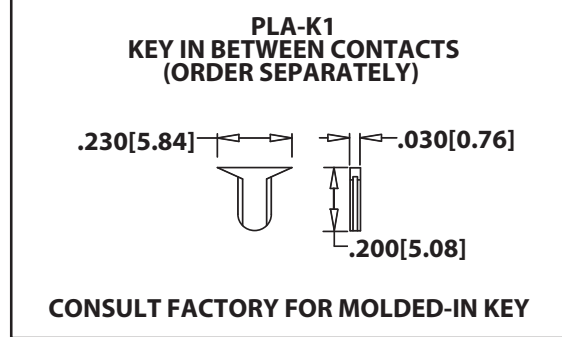

TERMINATION TYPE

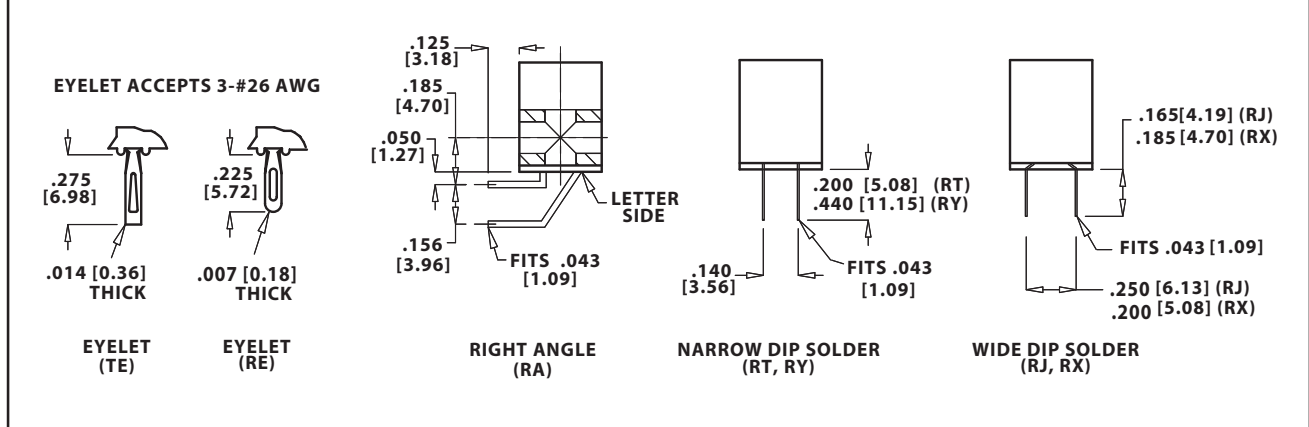

MOUNTING STYLE

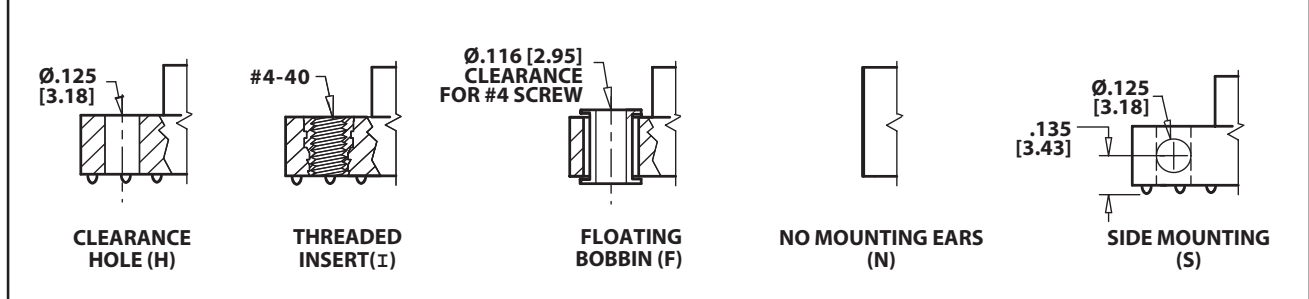



**.125" [3.18mm] Contact Centers, .431" Insulator Height
Dip Solder/Eyelet/Right Angle for .062" [1.57] or .031" [0.79] Mating PCB**

Sullins Edgecards

PART NUMBER CODING

E B A 43 D R E H - Sxxx

MATERIALS (Insulator/Contact)

- E = PBT/Phosphor Bronze (Standard)
- R = PPS/Phosphor Bronze
- G = PA9T/Phosphor bronze
- H = PBT/Beryllium Copper
- A = PPS/Beryllium Copper
- J = PA9T/Beryllium Copper
- *F = PPS/Spinodal (Overall Gold Plating Only)
Consult Factory for Special Soldering Guidelines
- *C = PPS/Beryllium Nickel (Overall Gold Plating Only)
- *W = PEEK/Beryllium Nickel (Overall Gold Plating Only)
*Consult Factory for availability.

CONTACT FINISH - RoHS Compliant
All platings are Lead Free and have .000050" Nickel underplate

	Contact Surface	Termination
B =	.000010" Gold	.000100" Pure Tin, Matte
C =	.000030" Gold	.000100" Pure Tin, Matte
G =	.000010" Gold	.000005" Gold
Y =	.000030" Gold	.000005" Gold
	Contact Surface	Overall Plating
S =	.000010" Gold	.000010" Gold
M =	.000030" Gold	.000010" Gold
E =	.000100" Pure Tin, Matte	.000100" Pure Tin, Matte

MODIFICATION CODE (Consult Factory)
OMIT FOR STANDARD

- S13 = Card Extender Accepts .062"[1.57] PCB (RT, RE, RY Terminations Only)
- S734 = .031" ± .008" [1.79 ± .20] Thick PCB

MOUNTING STYLE (Opposite Page)

- H = .125"[3.18mm] Clearance Holes
- N = No Mounting
- S = Side Mounting
- I = Threaded Insert
- F = Floating Bobbin

TERMINATION TYPE (Opposite Page)

- RA = Right Angle
- RE = Eyelet (Standard)
- TE = Eyelet (Overall Plated Only)
- RT = .140"[3.56mm] x .200"[5.08mm] Dip Solder
- RY = .140"[3.56mm] x .440"[11.18mm] Dip Solder
- RX = .200"[5.08mm] x .185"[4.70mm] Dip Solder
- RJ = .250"[6.35mm] x .165"[4.19mm] Dip Solder

READOUT (Opposite Page)

- D = Dual
- H = Half Loaded

NUMBER OF CONTACT POSITIONS
See Chart Below

CONTACT CENTERS
A = .125"[3.18mm]

DIMENSIONS

Dimensions in [] are in millimeters, all others are in inches.

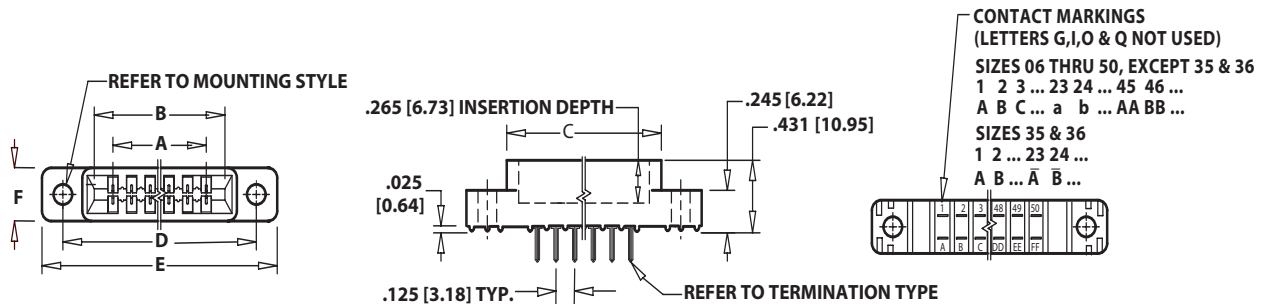

Tolerances with PPS Insulator Material may vary slightly due to shrinkage differential: Consult Factory.

Positions/ Contacts	INCHES						[MILLIMETERS]					
	A±.008	B±.008	C±.015	D±.010	E±.020	F±.005	A±0.20	B±0.20	C±0.38	D±0.25	E±0.51	F±0.13
06/12	0.625	0.875	1.035	1.295	1.575	0.330	15.88	22.23	26.29	32.89	40.01	8.38
10/20	1.125	1.375	1.535	1.795	2.075		28.58	34.93	38.99	45.59	52.71	
14/28	1.625	1.875	2.035	2.295	2.575		41.28	47.63	51.69	58.29	65.41	
15/30	1.750	2.000	2.160	2.420	2.700		44.45	50.80	54.86	61.47	68.58	
18/36	2.125	2.375	2.535	2.795	3.075		53.98	60.33	64.39	70.99	78.11	
22/44	2.625	2.875	3.035	3.295	3.575		66.68	73.03	77.09	83.69	90.81	
28/56	3.375	3.625	3.785	4.045	4.325		85.73	92.08	96.14	102.74	109.86	
30/60	3.625	3.875	4.035	4.295	4.575		92.08	98.43	102.49	109.09	116.21	
31/62	3.750	4.000	4.160	4.420	4.700		95.25	101.60	105.66	112.27	119.38	
35/70	4.250	4.500	4.660	4.920	5.200		107.95	114.30	118.36	124.97	132.08	
36/72	4.375	4.625	4.785	5.045	5.325	111.13	117.48	121.54	128.14	135.26		
37/74	4.500	4.750	4.910	5.170	5.450	114.30	120.65	124.71	131.32	138.43		
40/80	4.875	5.125	5.285	5.545	5.825	123.83	130.18	134.24	140.84	147.96	9.40	
43/86	5.250	5.500	5.660	5.920	6.200	133.35	139.70	143.76	150.37	157.48		
44/88	5.375	5.625	5.785	6.045	6.325	136.53	142.88	146.94	153.54	160.66		
49/98	6.000	6.250	6.410	6.670	6.950	152.40	158.75	162.81	169.42	176.53		
50/100	6.125	6.375	6.535	6.795	7.075	155.58	161.93	165.99	172.59	179.71		